

SECTION G

#4 @ 12" O.C., BOTHWAYS TO BE USED WHEN B IS 60" OR GREATER

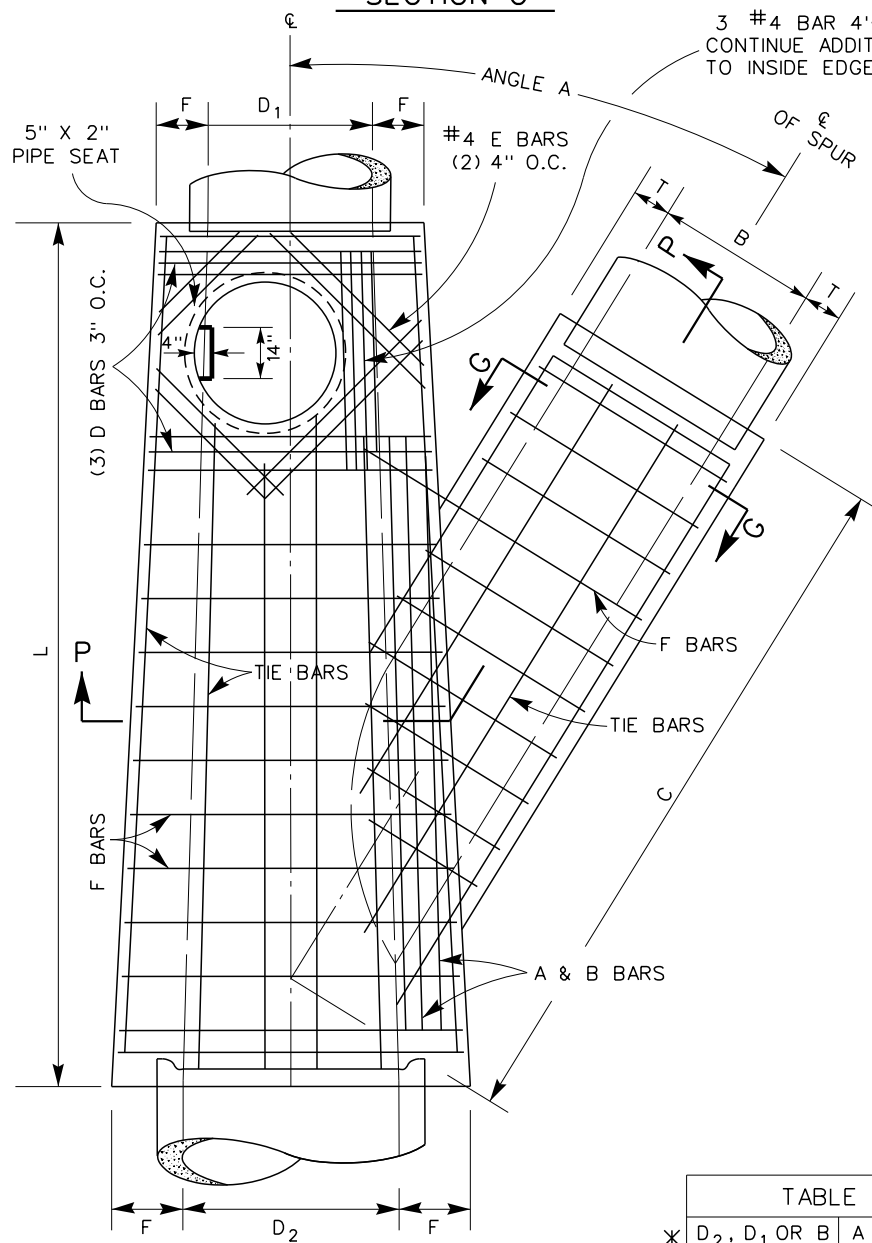

PLAN (SHAFT NOT SHOWN)

TABLE OF BAR SIZES		
D <sub>2</sub> , D <sub>1</sub> OR B	A & B BARS	D & F BARS
12" - 39"	#5 @ 3"	#4 @ 6"
42" - 84"	#6 @ 3"	#5 @ 6"
90" - 144"	#7 @ 3"	#6 @ 6"

X USE D<sub>2</sub>, OR D<sub>1</sub>, WHICHEVER IS GREATER, OR B

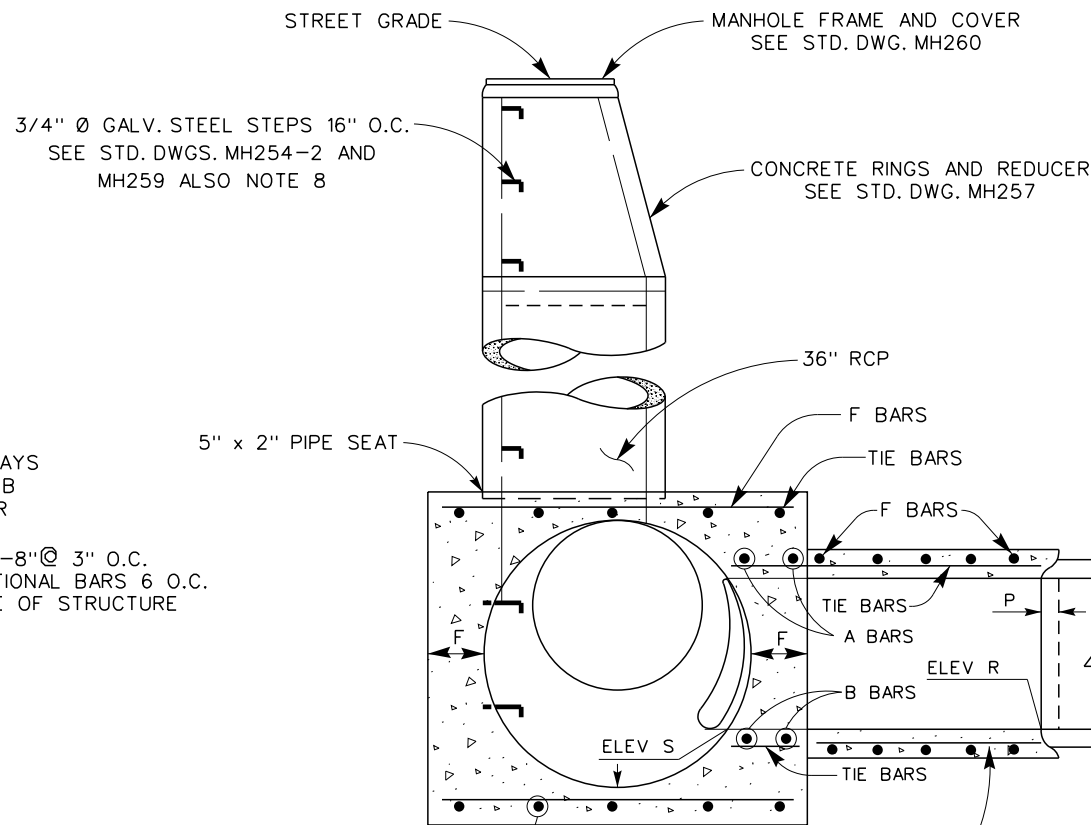

SECTION P

#4 @ 12" O.C., BOTHWAYS TO BE USED WHEN B IS 60" OR GREATER

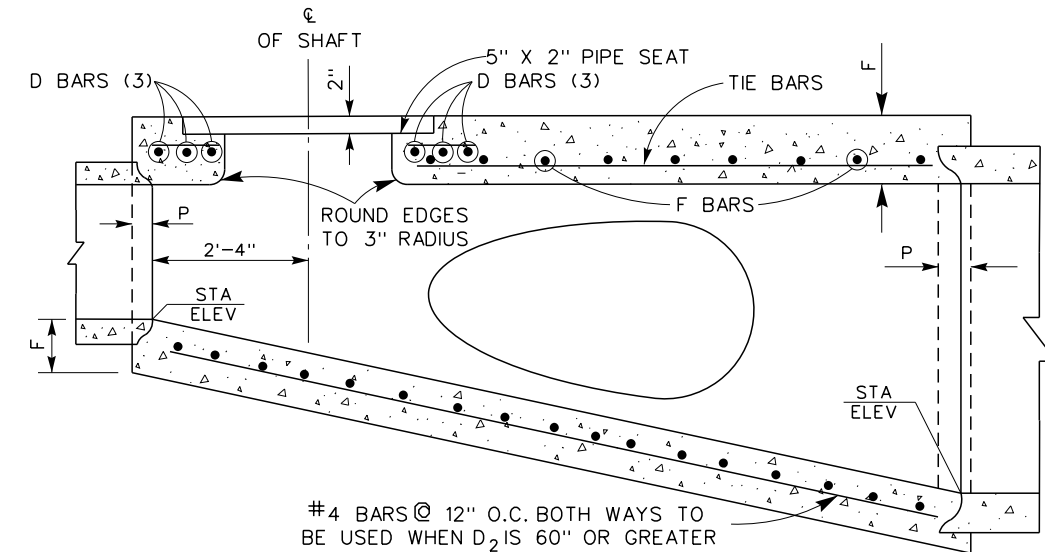

LONGITUDINAL SECTION

#4 BARS @ 12" O.C. BOTHWAYS TO BE USED WHEN D<sub>2</sub> IS 60" OR GREATER

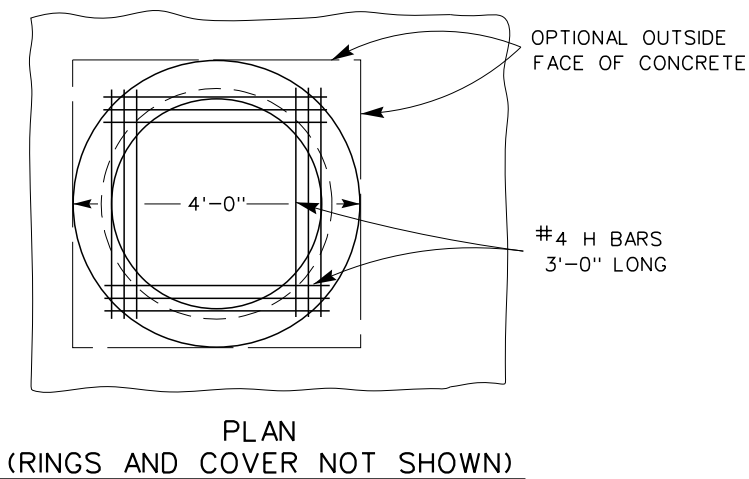

PLAN (RINGS AND COVER NOT SHOWN)

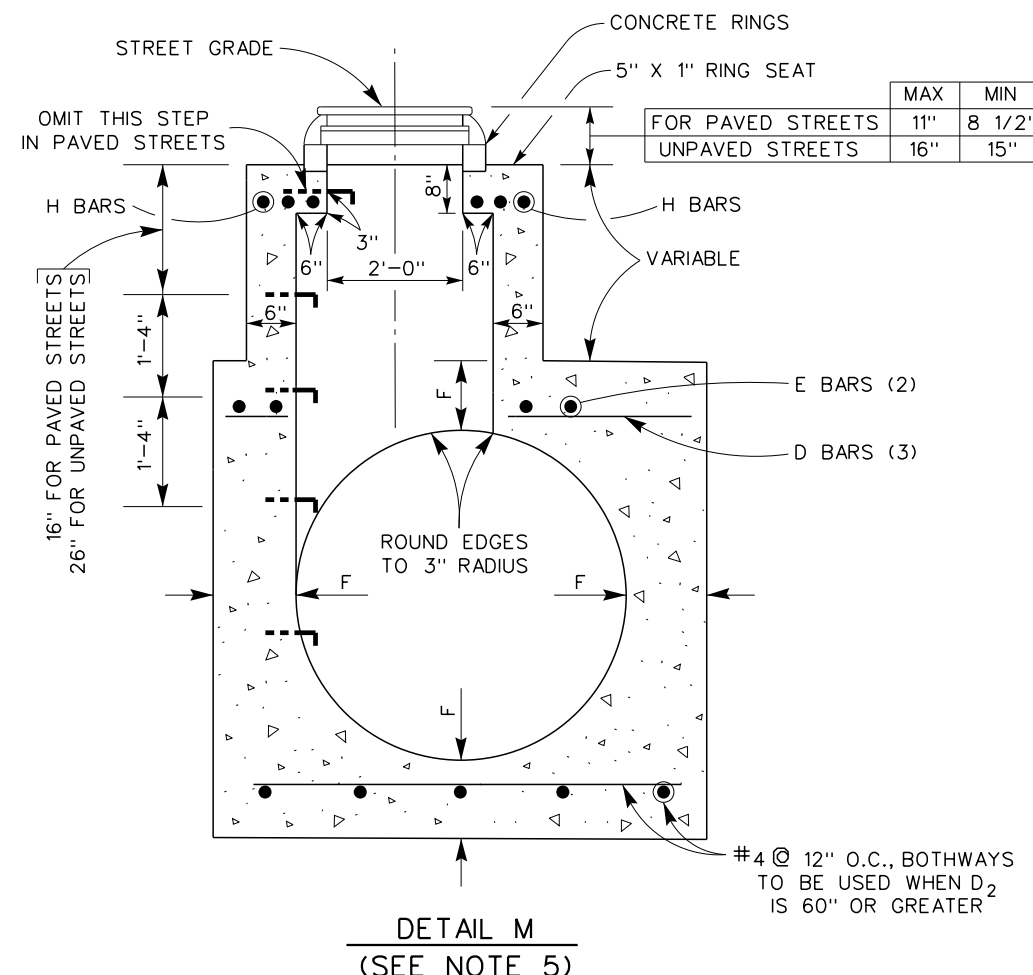
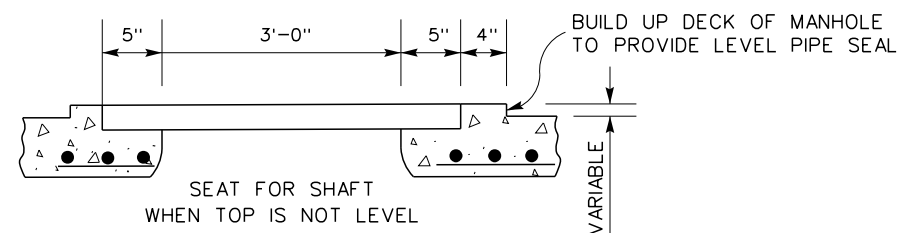

DETAIL M (SEE NOTE 5)

	MAX	MIN
FOR PAVED STREETS	11"	8 1/2"
UNPAVED STREETS	16"	15"

RIVERSIDE COUNTY FLOOD CONTROL AND WATER CONSERVATION DISTRICT

RECOMMENDED FOR APPROVAL BY: *[Signature]*  
 CHIEF, DESIGN & CONSTRUCTION  
 DATE: JANUARY 2011 R.E. No. 44684

APPROVED BY: *[Signature]*  
 CHIEF ENGINEER  
 DATE: JANUARY 2011 R.C.E. No. 32336

MANHOLE NO. 4  
 STANDARD DRAWING NUMBER MH254  
 SHEET 1 OF 2